

# Tire Changer Accessories



# Revolution™ accessories

The standard Revolution tire changer comes equipped to handle virtually all tire and wheel combinations.

<b>A</b>	<b>RP6-3784</b>	Paste
<b>B</b>	<b>RP6-1506</b>	Paste brush
<b>C</b>	<b>69-1394-2</b>	Pin protector (2)
<b>D</b>	<b>221-759-2</b>	Valve core remover
<b>E</b>	<b>221-659-2</b>	Bead starting tool
<b>F</b>	<b>RP11-2020688</b>	Valve puller
<b>G</b>	<b>192-233-1</b>	In-between cone (2)
<b>H</b>	<b>192-225-1</b>	Small polymer cone (2)
<b>I</b>	<b>192-226-1</b>	Double-sided polymer cone (2)
<b>J</b>	<b>111-154-1</b>	Spare roller
<b>K</b>	<b>179-15-2</b>	Glasses
<b>L</b>	<b>221-713-2</b>	Polymer mount head (2)
<b>M</b>	<b>69-1392-2</b>	Rubber platten cover (2)



*The following options can be used to enhance serviceability of specialized applications.*



### Flange plate kit 20-3158-1

Ideal for plastic clad wheels or reverse wheels where maximum protection is needed. Maximum diameter 240 mm.

*Standard with TCR1S*



### Camera kit 20-2945-1

Camera kit records tire changing. Can be used to verify correct usage and training.

*Suitable for TCR1 (not S)*



### Dual wheel adaptor 20-2964-1

Optional adaptor adds clamping capability for dual wheels, 19.5 in. wheels and other wheels with large center holes.

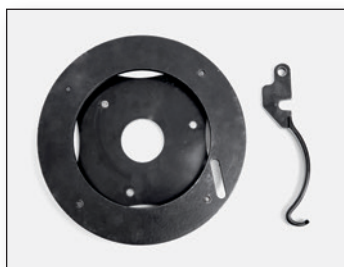

### Thick bead kit 20-3160-1

Wider hook for thicker beads. Suitable for skid steer, load range G-H-J-tires. Plus, reverse wheel plate for 19.5- and 17.5-in. rims.



TCR1S

# TCA-series accessories

The standard Auto34S tire changer comes equipped to handle virtually all common tire and wheel combinations.

<b>A</b>	<b>RP6-G1000A80</b>	Quick clamp
<b>B</b>	<b>RP6-710090480</b>	Pin protector (2)
<b>C</b>	<b>RP6-710012940</b>	Pin extension
<b>D</b>	<b>145-341-2</b>	Air chuck
<b>E</b>	<b>RP6-710090730</b>	Traction bar
<b>F</b>	<b>148-133-2</b>	Lubrication oil
<b>G</b>	<b>179-15-2</b>	Glasses
<b>H</b>	<b>221-659-2</b>	Bead starting tool
<b>I</b>	<b>RP6-3784</b>	Paste
<b>J</b>	<b>RP6-1506</b>	Paste brush
<b>K</b>	<b>RP6-710013421</b>	Support plate cover (2)
<b>L</b>	<b>RP6-710014120</b>	Toolhead (2)
<b>M</b>	<b>RP6-1157</b>	Two-sided cone
<b>N</b>	<b>RP6-G1000A86</b>	Mirror



*The following options can be used to enhance serviceability of specialized applications.*



## Flange plate kit RP6-G1000A87

Optional kit is ideal for plastic-clad wheels or reverse wheels where maximum protection is needed.



## Basic flange plate RP6-G1000A123

Optional kit handles plastic-clad wheels without the need of reverse applications.



## Contoured Press Head

Bead press head for special applications. Required by BMW.

TCA34S use **RP6-G1000A111** (pictured)  
TCA34 use **RP6-G1000A94**



## PAX® tire system kit RP6-G1000A73

Optional kit for servicing Michelin® PAX® systems. (TCA34S & TCA34 only)

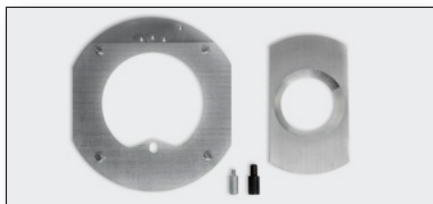

## 19.5 inch adaptor – 20-2341-1

Adds clamping capability for 19.5 in. wheels with large center holes.



TCA34S

# TC-series standard accessories

Each Hunter TC-series tire changer includes a variety of accessories to help service a wide range of tire and wheel combinations.

			TC3715	TC3700	TC3315	TC3305	TC3300
<b>A</b>	<b>20-2502-1</b>	Bead press arm	✓		✓		
<b>B</b>	<b>20-2565-1</b>	Plus arm device				✓	
<b>C</b>	<b>RP6-G1000A80</b>	Quick clamp	✓	✓	✓	✓	✓
<b>D</b>	<b>179-15-2</b>	Safety glasses	✓	✓	✓	✓	✓
<b>E</b>	<b>148-133-2</b>	Lubrication oil	✓	✓	✓	✓	✓
<b>F</b>	<b>RP6-3784</b>	Mounting paste	✓	✓	✓	✓	✓
<b>G</b>	<b>RP6-1506</b>	Paste brush	✓	✓	✓	✓	✓
<b>H</b>	<b>RP6-710090730</b>	Traction bar					
<b>I</b>	<b>RP6-G1000A67</b>	28" bead depressor tail w/ traction bar	✓	✓			
<b>J</b>	<b>RP6-1157</b>	Two-sided cone	✓	✓			
<b>K</b>	<b>RP6-G1000A7</b>	Mechanical bead roller	✓	✓			
<b>L</b>	<b>RP6-710013421</b>	Support plate cover (2)	✓	✓	✓	✓	✓
<b>M</b>	<b>RP6-G800A11</b>	Shovel protector (2)	✓	✓	✓	✓	✓
<b>N</b>	<b>221-675-2</b>	Extra mount head	✓	✓	✓	✓	✓
<b>O</b>	<b>RP6-710090480</b>	Pin protector (2)	✓	✓	✓	✓	✓
<b>P</b>	<b>RP6-710012940</b>	Drive pin extension	✓	✓	✓	✓	✓
<b>Q</b>	<b>RP6-0326</b>	Bead protector sleeve	✓	✓			
<b>R</b>	<b>145-341-2</b>	Air chuck	✓	✓	✓	✓	✓
<b>S</b>	<b>RP6-G1000A11</b>	"HM" bead lever	✓	✓			



TC3715SS



TC3700SS

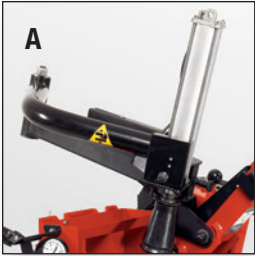

**Bead press arm – 20-2502-1**

Suitable for TC3700, TC3510, TC3500 and TC3300 series tire changers.

*Standard on TC3715.*



**Plus arm device – 20-2565-1**

Suitable for TC3300 model tire changers.

*Not compatible with TC3250.*

*May not be combined with bead press arm [20-2502-1].*



TC3305



TC3300

# TC-series accessories

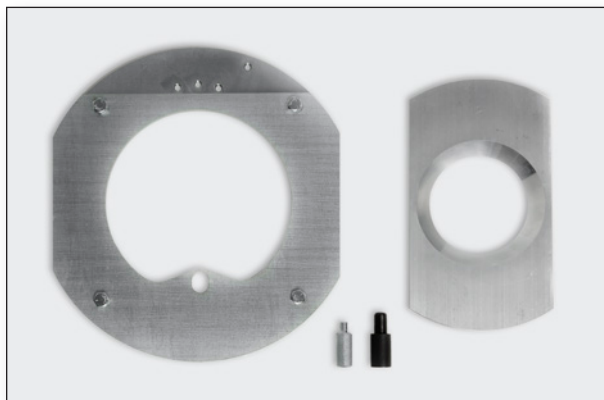

## 19.5-inch truck center cone adaptor kit 20-2341-1

Adapts large center-bore wheels to center-clamp tire changers (TC3700, TC3300, TCA34, TCA28).



## Rubber protection plate for center-clamp tire changers – RP6-710013421

Soft, rubber plate protects rim when servicing reverse wheels. Intended to be removed when not servicing reverse wheels.



## Flange plate for center-clamp tire changers RP6-G1000A87

Useful for plastic-faced wheels and/or reverse wheels where maximum finish protection is needed. Max diameter 230mm.



## Flange plates for clad wheels RP6-G1000A123

For plastic-faced wheels only.



## Long flange plate pins RP6-G1000A102

Optional pins are longer, allowing servicing of reverse wheels with extra deep spokes. For use with Hunter center-clamp flange plate [RP6-G1000A87].



## Short drive pin – 135-486-2

Useful when servicing some reverse wheels. Also useful in combination with older [20-2341-1] 19.5 kits and GM 16 in. dually wheel service.

Standard with 19.5 in. kit [20-2341-1].



## Drive pin protectors for center-clamp tire changers RP6-710090480

Plastic cap protects lug holes of reverse wheels when clamped face down.



**Polymer mount head (1 ea.) – 221-675-2**

Rides closer than steel designs, reducing stress to beads when demounting and mounting low-profile tires. Wear component designed to protect the tire and rim.

**221-675-2-B** Polymer mount heads (6 ea.)

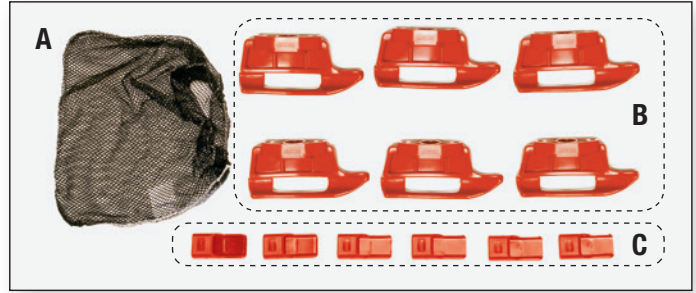

**Polymer head maintenance kit – 20-1506-1**

Provides convenient way to store maintenance items at the tire changer. *Kit includes:*

- A** | **166-51-2** | Nylon mesh storage bag
- B** | **221-675-2** | Polymer mount heads (6 ea.)
- C** | **RP6-0326** | Bead lever protector sleeves (6 ea.)



**Rimsled & mount head kit – RP6-G1000A91K**

Provides additional protection for painted or plastic-clad rims. Rimsled only fits “black” mount heads supplied in kit.

- A** | **RP6-G1000A14** | Individual mount head
- B** | **RP6-12916** | Rim protector (box of 50)



**Plastic shovel protectors (1 ea.)  
RP6-G800A11**

Clip-on side shovel protectors prevent damaging metal-to-metal contact when bead loosening.



*Shown (below) with optional 28" bead depressor tail with traction beam.*

**Mounting belt kit  
RP6-G1000A8**

For mounting and matching difficult ultra-low-profile and runflat tires.



**Mechanical bead roller – RP6-G1000A7**

Pushes the upper bead of the tire below the right hand area of the mount head keeping the tire in the proper location during mounting. Eliminates extra work to mount stiff tires.

## TC-series accessories cont.



**Storage bracket  
RP6-7900113100**

For storage of the center-shaft or center support when not in use. Attaches to the storage tray by drilling two small holes.



**External rubber clamping jaw  
for TC35XX / TC3250 (1 ea.)  
RP6-8659**

For external clamping of reverse rims. Not compatible with first generation RP6-4177.



**Shaft extender – RP6-790012540**

Useful to extend the clamping shaft when used with older RP6-G1000A87 flange plates. Standard with all new flange plates.



**Two-sided cone for LT wheels  
RP6-1157**

For use with the regular-sized clamping cone when the wheel hub bore is larger than the standard cone.



**Cone cover, wheel hub protector  
RP6-1156**

Protects the wheel hub bore from contact when center-clamping.



**Wide toolhead – RP6-710014120**

Suitable for TCA34S, TCA34 and TCA28 tire changers with serial numbers 664 and above.



**Force multiplier – RP6-G1000A23**

Adds leverage when seating the mount head and holding it down against the wheel.

Suitable for TC3300 and early TC3700 prior to vertically-locking mounthead.

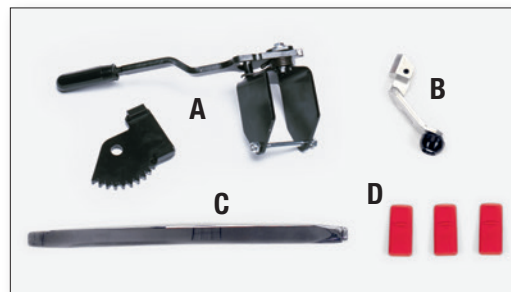

**Plus kit for TC3300 – 20-2707-1**

*Includes:*

<b>A</b>	<b>RP6-G1000A23</b>	Force multiplier
<b>B</b>	<b>RP6-G1000A7</b>	Mechanical bead roller
<b>C</b>	<b>RP6-G1000A11</b>	"HM" bead lever
<b>D</b>	<b>RP6-0326</b>	Bead lever protector sleeves (3 ea.)



# PAX® tire system tools & kits



		TC3900 / TC3700 All generations 20-2268-1	TC3500 20-1795-1
<b>A</b>	<b>RP6-14783</b>	PAX arm with large roller	✓
<b>B</b>	<b>RP6-41942</b>	PAX arm with small roller (2)	✓
<b>C</b>	<b>221-684-2</b>	Ratchet strap	✓
<b>D</b>	<b>RP6-8703</b>	Brass shaft protector	✓
<b>E</b>	<b>RP6-11522</b>	Quick-disconnect shaft	✓
<b>F</b>	<b>RP6-1156</b>	Short cone rim protector	✓
<b>G</b>	<b>RP6-1460</b>	Short cone (2)	✓
<b>H</b>	<b>RP6-4153</b>	Stroke limiters	✓
<b>I</b>	<b>RP6-4100001</b>	PAX bead levers (2)	✓
<b>J</b>	<b>RP6-7042</b>	Plastic rim protectors (4)	✓

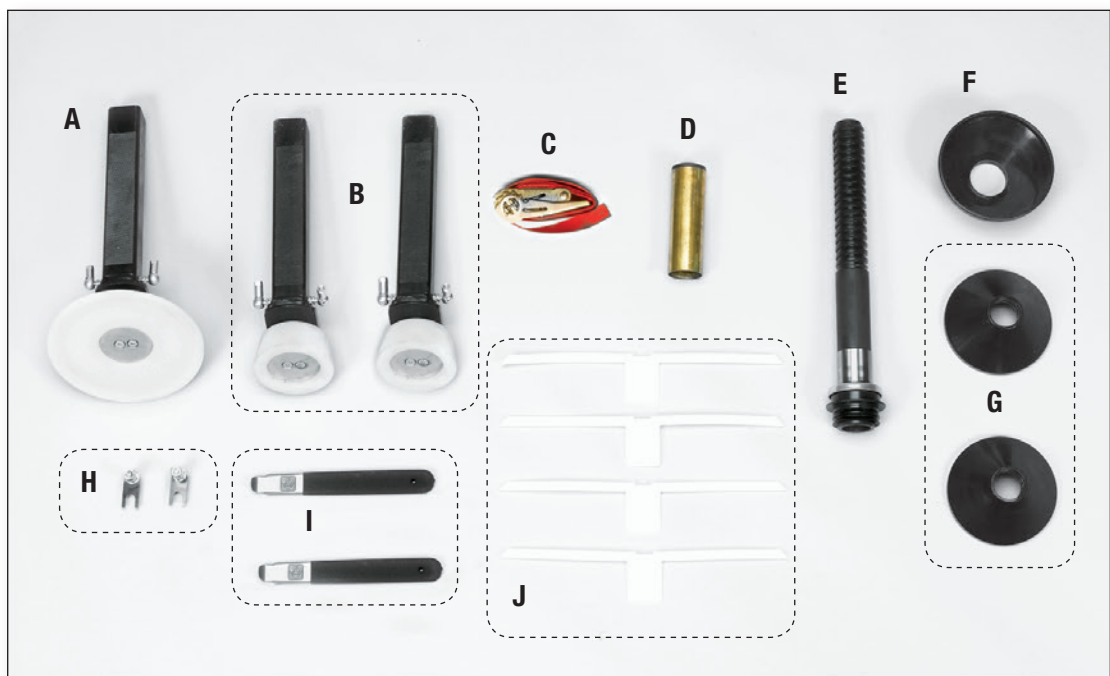

*PAX upgrade kits used to upgrade early TC3500's may also require the quick-disconnect coupling bolt and center support kit [RP6-10822] to utilize the newly upgraded quick-disconnect threaded center shaft [RP6-11522] supplied in the newer PAX upgrade kits.*

# TCX-series standard accessories

Hunter TCX-series tire changers include a variety of accessories to help service a wide range of tire and wheel combinations.

			TCX57	TCX56	TCX53L	TCX53	TCX51L	TCX51	TCX50
<b>A</b>	<b>Leverless</b>	Leverless mount head	✓		✓		✓		
<b>B</b>	<b>BPS</b>	Bead press system w/ two roller arms & lift/disk	✓	✓	✓	✓			
<b>C</b>	<b>BP</b>	Single bead press arm					✓	✓	
<b>D</b>	<b>RP11-4-403749</b>	BP press cone					✓	✓	
<b>E</b>	<b>RP11-2121350</b>	Large pressing cone	✓	✓	✓	✓			
<b>F</b>	<b>RP11-2413305</b>	Small pressing cone	✓	✓	✓	✓			
<b>G</b>	<b>RP11-2202239</b>	Pressing cone extension	✓	✓	✓	✓			
<b>H</b>	<b>RP6-3784</b>	Mounting paste 3.5 kg	✓	✓	✓	✓	✓	✓	✓
<b>I</b>	<b>RP6-1506</b>	Applicator brush	✓	✓	✓	✓	✓	✓	✓
<b>J</b>	<b>RP11-8-11100402</b>	Jaw extender & reducer	✓	✓					
<b>K</b>	<b>RP11-8-11100358</b>	Hi-grip jaw protector	✓	✓	✓	✓	✓	✓	✓
<b>L</b>	<b>145-341-2</b>	Tire inflator/air chuck	✓	✓	✓	✓	✓	✓	✓
<b>M</b>	<b>RP11-8-11400327</b>	Bolt-on plastic head		✓		✓		✓	✓
<b>N</b>	<b>RP11-5-104797</b>	Bolt-on steel head		✓		✓		✓	
<b>O</b>	<b>179-15-2</b>	Safety goggles	✓	✓	✓	✓	✓	✓	✓
<b>P</b>	<b>RP11-5-490223</b>	Plastic shovel protector	✓	✓	✓	✓	✓	✓	✓
<b>Q</b>	<b>148-133-2</b>	Lubrication oil	✓	✓	✓	✓	✓	✓	✓
<b>R</b>	<b>RP11-8-11400098</b>	Bead lever protector sleeve	✓	✓	✓	✓	✓	✓	
<b>S</b>	<b>221-659-2</b>	Bead starting tool	✓	✓					
<b>T</b>	<b>RP11-8-11400325</b>	Leverless mount head inserts	✓		✓		✓		
<b>U</b>	<b>RP11-2202106</b>	Rim edge protector	✓	✓					
<b>V</b>	<b>RP11-2020688</b>	Valve stem puller	✓	✓					
<b>W</b>	<b>221-759-2</b>	Valve core remover	✓	✓					
<b>X</b>	<b>RP11-3009516</b>	Bead lever (standard)	✓	✓	✓	✓	✓	✓	✓
<b>Y</b>	<b>RP11-8-11100369</b>	Mount head inserts (traditional)		✓		✓		✓	



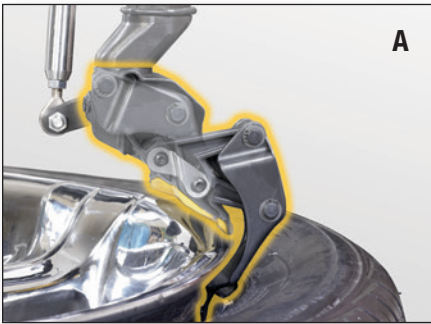

A

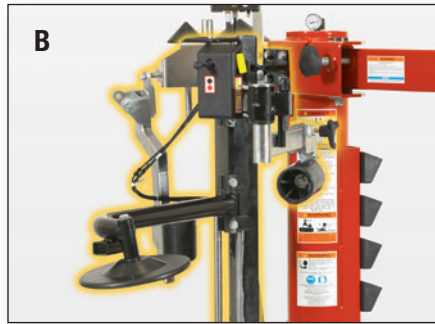

B



C



TCX53



TCX51



TCX50

# Bead assistance



## Bead press arm for TCX50 series 20-2833-1

- ✓ The pressing head pushes the tire into the drop-center when demounting stiff sidewall tires, greatly reducing lever effort and risk of bead damage.
- ✓ The standard press cone used with the bead press arm will press the rim onto the jaws for easier clamping of stiff tires.
- ✓ The standard bead press roller keeps stiff tires under the mount head and guides the bead.
- ✓ Lifting hook.
- ✓ Not suitable for older TCX5X5 variations.

*Standard with TCX51 (E, A or H models)*



### **PATENTED**

## Bead press system for TCX50 series 20-2834-1

- ✓ Uniquely centers the pressing capabilities over the center of the wheel and tire to ensure maximum service strength and rigidity.
- ✓ Provides effortless assistance with most difficult tires and custom wheels up to 26" diameter.
- ✓ Not suitable for older TCX5X5 variations.

### **Kit includes:**

- Bead press system with stationary arm, rotating arm & bead lifting arm
- Small pressing cone **RP11-2413305**
- Large pressing cone **RP11-2121350**
- Pressing cone extension **RP11-2202239**

*Standard with TCX53 (E, A or H models)*

# TCX-series accessories

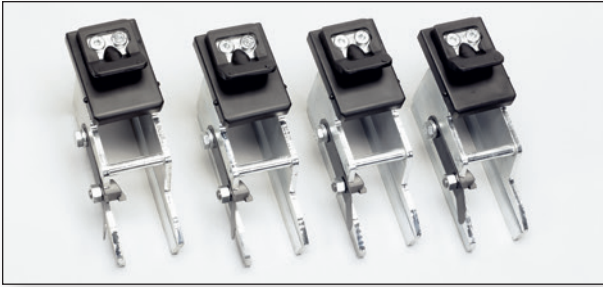

**Jaw extender & reducer (4 ea.)**  
**RP11-8-11100402**

Extends range by 4 inches. Reduces range by 5 inches.

**Note:** For small wheel service (6-8 in.), mount head will not reach and is too large. Standard practice is to clamp with adaptors and service with spoons.



**High grip jaw protectors (8 ea.)**  
**RP11-8-11100358**

Polymer jaw covers prevent metal-to-metal contact when performing external clamping.



**Motorcycle adaptor**  
**RP11-2200277**

Raise the clamping jaws to clear the integrated disc brake or drive sprockets used on motorcycle wheels. Plastic-covered to prevent damage to wheel.

**RP11-2309245**  
 Individual adaptor

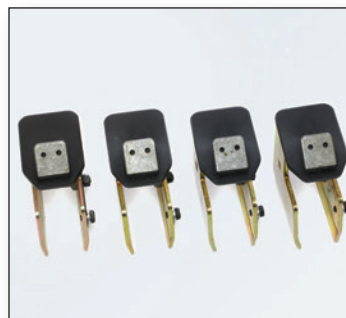

**Harley Davidson Wheel Adaptor**  
**RP11-2201113**

Raise clamping jaws to clear belt drive pulley and brakes used on Harley Davidson. Plastic-covered to prevent wheel damage.



**Plastic shovel protectors (4 ea.)**  
**RP11-5-490223**

Clip-on side shovel protectors prevent damage when bead loosening low-profile tires on expensive alloy wheels.



**Blast inflator**  
**RP11-8-11100403**

Direct bursts of compressed air to seat difficult beads

*Suitable for TCX50-53 only.*



**Storage tray for TCX505-535**  
**RP11-8-11400187**

One tray standard on all TCX500s. Second standard on TCX515. Each TCX500 can use up to 2 trays (two shown). Accessories available separately.

*Not suitable for TCX50 series.*



**Storage shelf**  
**20-2885-1**

Large steel shelf system expands storage capacity.

*Suitable for TCX50-53 only.*

# TCX-series mount heads and accessories

## Plastic mount heads



**NEW** "Wing" plastic mount head upgrade for new tire changers – RP11-8-11400328

Includes 2 plastic heads and hardware to add rotation.

Suitable for TCX50 serial numbers higher than IKE721041 and TCX56 head kit serial numbers higher than VKI046785.



**NEW** "Wing" plastic mount head upgrade for older tire changers – RP11-8-11400329

Includes plastic head and all mounting hardware.

Suitable for TCX50 serial numbers lower than IKE721041 and TCX56 head kit serial numbers lower than VKI046785. Also suitable for all older TCX565, 550, 5x5 and 500 tire changers.



**NEW**

"Wing" plastic mount head  
RP11-8-11400327



**Plastic mount head  
RP11-8314813**

Old mount head fits all TCX-series tire changers

## Leverless mount head accessories

### For V1 & V2 heads



Leverless mount head inserts  
(10 ea.) – RP11-8-11400293



Right side plastic protectors  
for leverless mount heads  
(10 ea.) – 20-2684-3

**NEW** For V3 heads



Leverless mount head inserts  
(10 ea.) – RP11-8-11400325

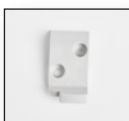

Single leverless  
mount head  
right-side insert  
RP11-8-1110326S

### For V1, V2 & V3 heads



Rear plastic protectors  
(10 ea.) – 20-2685-3



Replacement screw  
for protector  
(3 required)  
RP11-2-03438

## Steel mount heads & accessories



### Steel mount head (1 ea.) – RP11-5-104797

Replacement steel mount head. Current "slim" design fits all models and generations.



### Steel mount head (1 ea.) – RP11-5-400439

Large-knob legacy design. Fits all models and generations.

### Plastic protectors for new steel mount heads (10 ea.)

#### RP11-8-11100369

Polymer inserts for new TCX-series steel mounting head (RP11-5-104797) shown above.

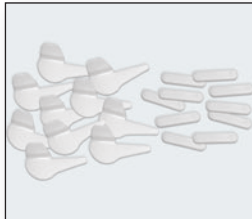

### Plastic protector kit for old steel mount heads (10 ea.)

#### RP11-8-11400096

For use with old TCX-series steel mounting head (RP11-5-400439) shown above.



### Plastic protector for new steel mount heads (1 ea.)

#### RP11-8-1110385S

For use with new TCX-series steel mounting head (RP11-5-104797) shown above.



### Single front plastic protector for old steel mount heads (1 ea.)

#### RP11-8-11100303S

Polymer insert for old TCX-series steel mounting head (RP11-5-400439) shown above.



### Mechanical bead roller for TCX505-550 standard heads

#### RP11-5-400900

Optional feature used to mount stiff low-profile tires. Eliminates extra work to mount stiff tires.

Not needed when using new "wing style" mount heads.

Use **RP11-8-11100327** for leverless heads.

# Wheel lift systems

Servicing large, heavy SUV, light-truck and custom wheels requires extra effort. The optional pneumatic wheel lift helps prevent potential injuries and fatigue from lifting heavy wheels into place.

The pedal-controlled wheel lift quickly raises the wheel, leaving the technician's hands free to control and position it on the tire changer clamping system.

A wheel lift can be ordered with newly purchased tire changer or separately as a retrofit kit. See the chart below for part numbers.

Base tire changer	Model number with wheel lift included	Wheel lift part number if ordered separately
TCA34	TCA34W	20-2236-1
TC3900	TC3900W	20-2944-1
TC3700	TC3700W	20-2944-1
TC3715	TC3715W	20-2944-1
TCX575	TCX575W	20-2044-1
TCX565	TCX565W	20-2044-1
TCX550EBPS	TCX550EWBPS	20-2044-1
TCX57	TCX57W	20-2045-1
TCX56	TCX56W	20-2045-1
TCX53E	TCX53EW	20-2045-1
Other TCX50-500	—	20-2045-1



*TC3715SS shown with optional 20-2944-1 wheel lift system*



*TCX57 shown with optional 20-2045-1 wheel lift system*



*TCA34 shown with optional 20-2236-1 wheel lift system*



*Integrated wheel lifts boost productivity and help prevent injury and fatigue*



*The Hunter wheel lift system makes servicing large wheels easy! Roll the wheel on the lift...*

*... activate the automated lifting device by pressing the lift foot pedal.*

*The lift automatically raises the wheel to an ergonomic height. Simply position wheel as needed. It's that easy!*



# Heavy-duty tire changer standard accessories

			TCX625HD	TCX625PHD	TCX640HD
A	RP11-8-12100040	Wheel ramp (2 included)		✓	
B	RP11-12100039	Pocket V cover		✓	
C	RP11-2105943	Tube tire bead guide			✓
D	RP11-3006365	Standard lever			✓
E	RP11-2105954	Truck bead lever	✓	✓	✓
F	RP11-8-12100181	Mounting lever (steel & ALU heads)		✓	
G	RP11-2200041	Alloy wheel clamp jaws (4)			✓
H	RP11-801254494	Aluminum jaw covers (4)		✓	
I	RP11-2005957	Steel wheel clamp	✓	✓	✓
J	RP11-2306808	Alloy wheel clamp	✓	✓	✓
K	RP6-3784	Mounting paste	✓	✓	✓
L	RP6-1506	Brush	✓	✓	✓

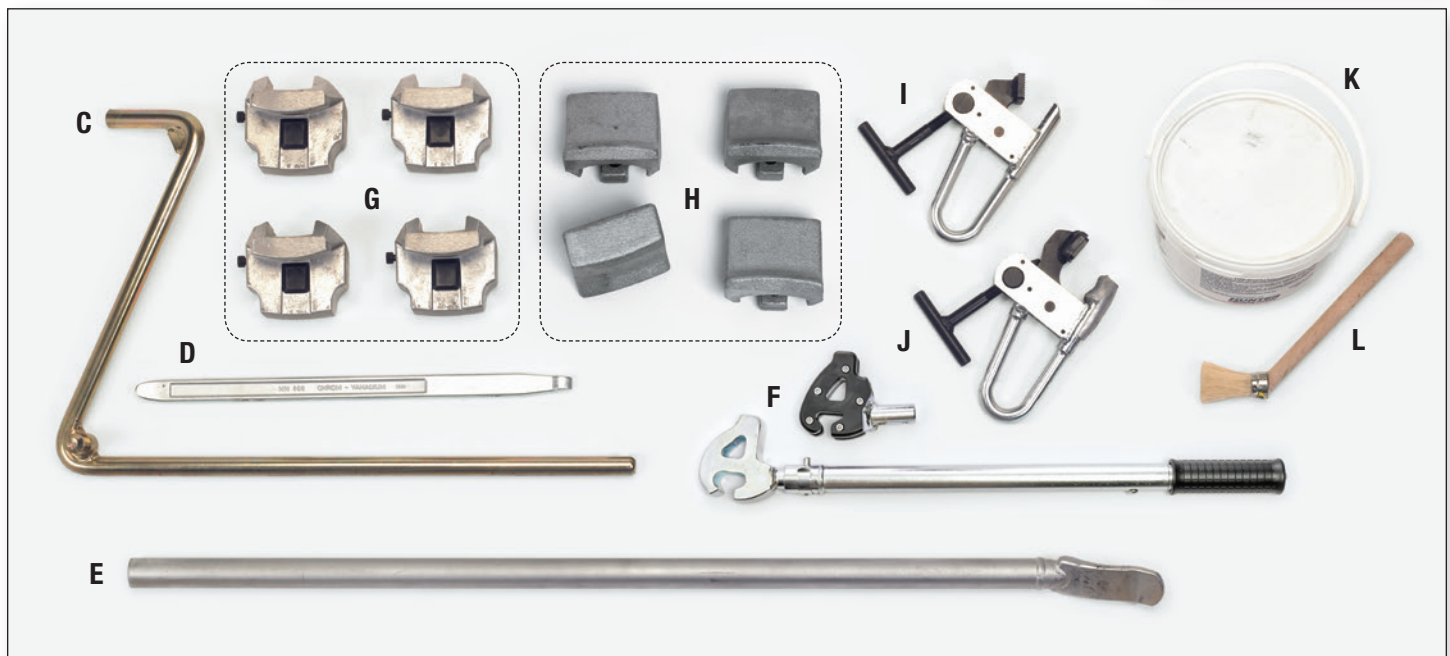
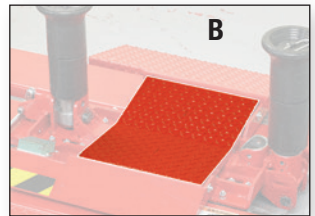
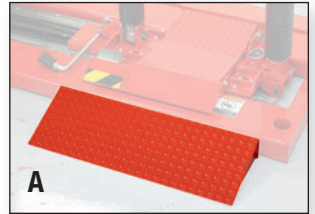

TCX625HD



TCX640HD

# Heavy-duty tire changer optional accessories

## TCX625HD



**Centerless wheel jaw adaptors**  
**RP11-8-12100176**

Service centerless wheels by securely gripping the inboard edge.



**Aluminum jaw covers**  
**RP11-801254494**

Prevents center-bore damage on aluminum wheels.

*Standard with TCX625PHD*



**Mounting lever**  
**RP11-8-12100181**

Speeds outside bead mounting.

Includes steel wheel and ALU wheel heads.

*Standard with TCX625PHD*

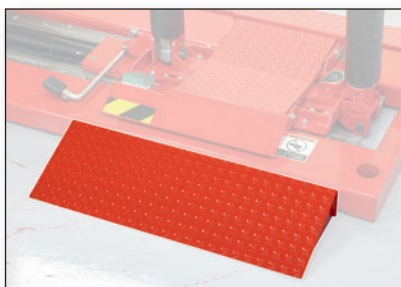

**Single ramp**  
**RP11-8-12100040**

Ease rolling tire onto changer.

One included

*Standard with TCX625PHD*

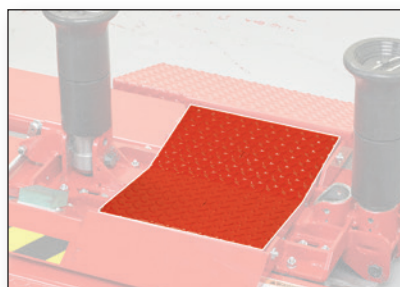

**Pocket V cover**  
**RP11-12100039**

Dress up cover for carriage.

*Standard with TCX625PHD*

## TCX640HD



**Tubeless roller**  
**RP11-2306040**

Eases bead loosening, mounting and demounting of tubeless truck and bus tires.



**Drop-center clamp**  
**RP11-801251904**

For skidder and similar type tires

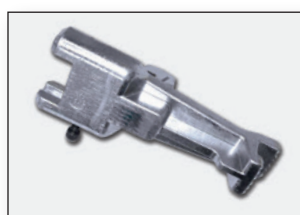

**Self-centering tulip chuck extensions (4 ea.)**  
**RP11-8-12100155**

Expands clamping size capacity to 56 inches.

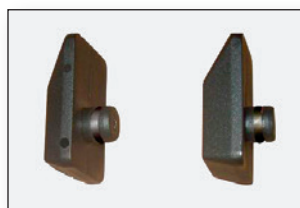

**Alloy jaws insert**  
**RP11-8-12100172**

For use on units with serial number iic735988 or greater.

# Universal accessories



## A. High-performance bead lever "HM" RP6-G1000A11

Patented, high-performance bead lever dramatically reduces servicing effort. A must for servicing low-profile tires.

## B. Bead lever protector sleeve – RP6-0326

Protects wheel flange by allowing the bead lever to slip out of the tire instead of being dragged against the rim during demounting.

**RP6-0326-B** Box of 10



## A. Traditional flat design bead lever – RP11-3009516

For demounting tires on conventional tire changers.

## B. Bead lever sleeve protectors (4 ea.) RP11-8-11400098

Protects wheel flange by allowing the bead lever to slip out of the tire instead of being dragged against the rim during demounting.

For use with RP11-3009516 Bead Lever Tool



## A. Valve core remover 221-759-2

## B. Rim edge protector RP11-2202106

## C. Valve stem puller RP11-2020688

## D. Bead starting tool 221-659-2

## Bead depressor tails helps position low-profile tires into drop-center for mounting & demounting

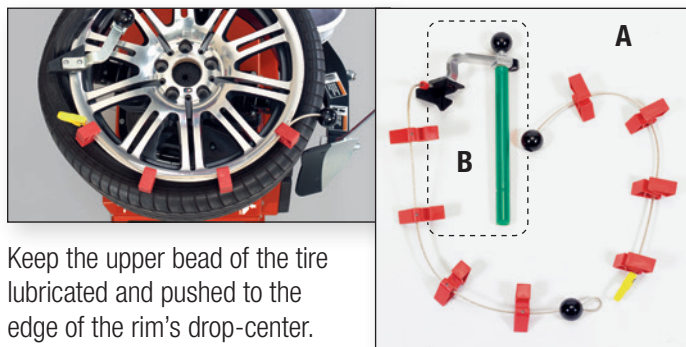

Keep the upper bead of the tire lubricated and pushed to the edge of the rim's drop-center.

## A. 28-in. bead depressor tail with traction bar RP6-G1000A67

Aids in locking tire to rim and pushing low-profile tires down into drop center for mounting. Services up to 28 in. diameter rims.

## B. Traction bar – RP6-710090730

Traction bar only. Used to lock tire to rim.

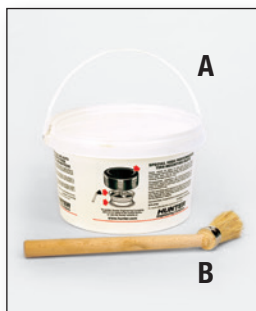

## A. Mounting paste (3.5 kg) – RP6-3784

Eases mounting of stiff low-profile tires. Aids in faster bead sealing during inflation. High-performance mounting paste is premixed to prevent incorrect mixing of water to liquid concentrates.

**RP6-3784-B** = 8 Buckets

**RP6-3784-BP** = 64 Buckets [1 pallet]

## B. Brush, angled applicator – RP6-1506

Provides proper application of mounting paste. Angled to allow easy access to the "toe area" of the bead most commonly damaged during mounting.



## Lubri-Oil air equipment lubrication 148-133-2

Lubri-Oil will not emulsify in water. When the lubricator becomes contaminated with water overflow from the regulator, the oil will separate. Available in 16-oz bottles. Twelve (12) to a case when ordered in quantity. Lubri-Oil weight is ISO32.



## Drop-center mounting clamp RP6-70210E

Helps position the bead into the drop-center. Not for extreme positive offset, flat-faced rims or soft-line flanges.

Alternative tools: RP6-1572, RP6-7290